

STINGER SCAN-150



MEGA LITE[®]

PRODUCT SPECIFICATION SHEET

DESCRIPTION

MEGA-LITE has re-amped the infamous scanner fixtures by creating the Stinger Scan-150. Designed to be more powerful and deliver a high output, this fixture features a 150W single color LED.

Packed with 8 colors+open, 7 removable, bi-directional, indexing rotation gobos and 4-facet, rotatable, indexing prism, the Stinger Scan-150 is ideal for creating dramatic eye-catching effects. Between the mechanical focus, 180° pan and 40° tilt it can deliver sharp optics and mid-air looks at a high-speed.

With a 15° lens angle, it produces impressive beams of light that are designed to deliver striking aerial effects. The fast mirror pace is suited for high energy music and high impact lighting that compliments other moving head effects.



POWERFUL

Designed to be more powerful and deliver a high output, this fixture features a powerful 150W single color LED.



FAST PAN & TILT

The 180° and 140° tilt can deliver high-speed optics and mid-air looks for dramatic eye-catching effects.



EFFECTS

The fixture is packed with 8 colors+open, 7 removable, bi-directional, indexing rotation gobos and a 4-facet, rotatable, indexing prism.

SOURCE

• LED TYPE: 150W SINGLE COLOR

OPTICAL SYSTEM

• LENS ANGLE: 15°
 • FOCUS: MECHANICAL FOCUS

EFFECTS

• COLORS: 8 COLORS + OPEN
 • ROTATING GOBOS: 7 REMOVABLE, BI-DIRECTIONAL, INDEXING
 • PRISM: 4-FACET, ROTATABLE, INDEXING

MOVEMENT

• PAN: 180°
 • TILT: 40°

CONTROL & PROGRAMMING

• RDM: YES
 • DISPLAY: DIGITAL
 • PROTOCOL: DMX 512
 • DMX CHANNELS: 2 MODES OF OPERATION

THERMAL & RATINGS

• MAX AMBIENT TEMP: 40° F (104° C)
 • MAX SURFACE TEMP: 140° F (60° C)
 • MAX OPERATING TEMP: 130° F (54° C)
 • COOLING: FAN COOLING

ELECTRICAL & CONNECTIONS

• POWER CONNECTIONS: PANEL MOUNTED POWER CON (TYPE) IN & OUT
 • DMX CONNECTORS: PANEL MOUNTED 5PIN XLR CONNECTOR IN & OUT (3 PIN OPTIONAL)
 • POWER SUPPLY: ELECTRONIC AUTO SWITCHING 100V-240V 50/60HZ
 • POWER CONSUMPTION: WATTS: 272W | AMPS: 2.3A
 • FUSE: F5A 250V

RIGGING:

• INSTALLATION SYSTEM: MOUNTING YOKE

ORDERING INFO:

• STINGER SCAN-150

PART NUMBER:

1205

INCLUDED ITEMS:

• POWER CON (TYPE) TO NEMA 5-15 CABLE
 • POWER CABLE
 • SAFETY EYEBOLT

ACCESSORIES:

• 4 UNIT ROAD CASE CAS-1205-4
 • 3 PIN CONNECTOR 1205-PCB-3PI
 • SHORT YOKE 1205-ACC-YOK



*Specifications subject to change

DIMENSIONS:

• FIXTURE SIZE: 10.5" X 6.5" X 18.5"
 • FIXTURE WEIGHT: 16.5 lb (7.5 kg)
 • PACKAGED SIZE: 23.25" X 12" X 20"
 • PACKAGED WEIGHT: 20 lb (9 kg)

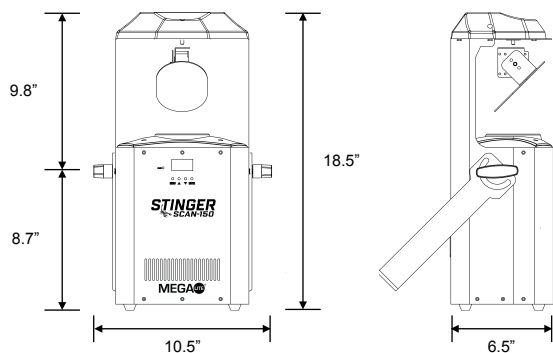
**GOBOS****COLORS**