

<sup>®</sup>  
**MEGALITE**

**DRAMA**  
**EW200**

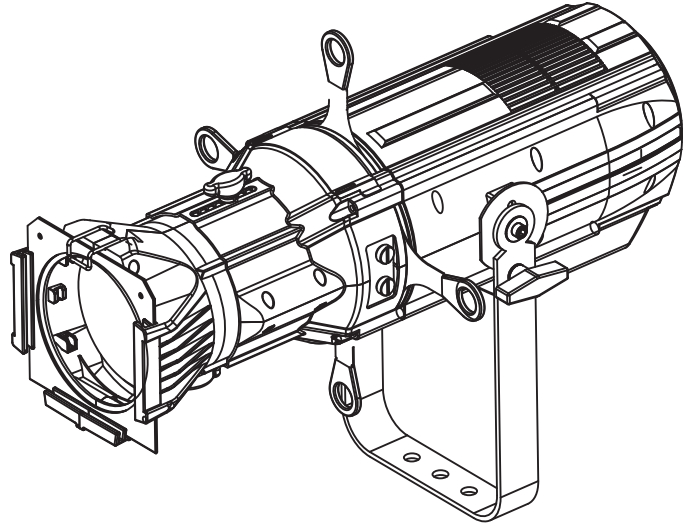

## **USER MANUAL**

### Table of Contents

Safety Information	2
What's Included	2
Specifications	3
Main Power Connection	4
DMX Connection	4
Menu Settings	5
DMX Profiles	6
Fixture and Lens Assembly	7
Gobo and Gel Holder	8
Size and Weight	9
Parts and Accessories	9
Installation	10
Warranty	11
Customer Service	12



Read all cautions and warnings  
prior to operation of this  
equipment

### Protection Against Fire



1. Maintain a minimum of 2 foot distance from any type of flame.
2. Fixture is designed for indoor use.
3. Do not install the unit too close to a heat source.
4. Make sure cables are properly secured.
5. Maximum surface operating temperature: 130°F.

### Protection Against Electrical Fire

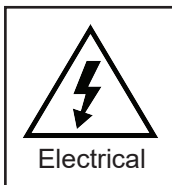

1. Disconnect power before servicing.
2. For connection to main power supply, proceed to page 4.
3. The power supply must be earthed (electronically grounded).
4. This fixture must not be left on for long periods of time.

### Protection Against Mechanical Hazards

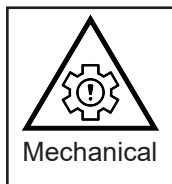

1. Use secondary safety attachment when hanging unit.
2. Use quality clamps or bolts when positioning unit.
3. Do not open unit while it is on. Risk of electrical shock.

### Ingress Protection

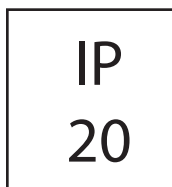

The IP rating is commonly expressed as IP (Ingress Protection) is followed by 2 numbers (i.e. 65) where the numbers define the fixture rating. The first number indicates the size of a particle that can enter the fixture.. The second number indicates the extent of protection against water entering the fixture. An IP20 rating in this fixture indicates that solid objects up to 12mm can't enter . And there is **NO** protection against water from entering the fixture..

### What is Included

- 1pc Drama EW200
- 1pc True-One type connection to  
Nema 5-15 Connection Cable
- 1pc User Manual
- 1pc Gobo Holder
- 1pc Gel Holder

# Specifications

---

## Part Numbers

---

### Fixture

7063 - Drama EW200

## Mechanical Specifications

---

<b>Display:</b>	Digital
<b>IP Rating:</b>	IP20
<b>Fastening System:</b>	Single Mounting Yoke
<b>DMX Connection:</b>	5 Pin XLR In and Out
<b>Power Connection:</b>	True-One type connection to NEMA 5-15
<b>Lens Angle:</b>	19, 26, 36, 50
<b>Lamp:</b>	COB LED
<b>Lamp Watts:</b>	200w

## Electrical Specifications

---

<b>Working Ambient Temp:</b>	24°f - 148°f
<b>Cooling:</b>	Fan Cooled
<b>Max Housing Temperature:</b>	130°F
<b>Color Temperature:</b>	6024k
<b>Power Consumption:</b>	185w   1.68 amps @110v
<b>Power Supply:</b>	HS-U400D42+12
<b>Power Input:</b>	100-240VAC 50/60Hz
<b>Power Link @ 110v:</b>	8

## Control & Programming

---

<b>Protocol:</b>	DMX 512
<b>DMX 3 Modes:</b>	1 ch: Dimmer 2 ch: Dimmer, Strobe 3 ch: Dimmer, Strobe, Dimmer Curve
<b>Operating Mode:</b>	DMX 512 and Manual Mode

## Main Power Connection

### Caution!

1. Do not connect to a dimmer system.
2. This unit has auto switching power supply. It will respond to 100-240VAC 50/60Hz automatically
3. Replace Fuse with specific type and rating. (T3.75AL 250V)
4. This unit must be earthed. (electronically grounded)

Cable USA	Cable EU	110V	220V
Black	Brown	Live	Live
White	Light Blue	Neutral	Live
Green	Yellow / Green	Ground	Ground

## DMX-512 Connection

The fixture is equipped with 5 pin XLR In and Out Sockets. The sockets are wired in parallel. Only use a shielded twisted pair cable designed for 5 pin XLR connectors in order to connect the controller with the fixture or the fixture with another.

### DMX 5 Pin XLR - Input / Output

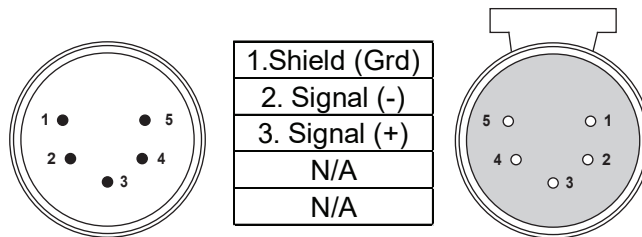

### Caution!

On the last fixture the DMX signal needs to be terminated with a terminator. Pre-manufactured terminator are available for purchase from your Mega Lite dealer item #P-DMX-T.

## Menu Settings

---

Upon powering on the unit, the display will show address information. The main menu can be accessed by pressing the ENTER button. Navigating the menu is achieved by using the UP/DOWN buttons. Pressing ENTER confirms selections and returns to the main menu.

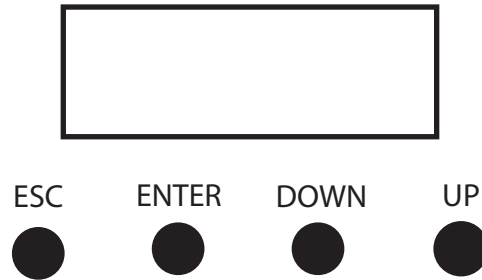

**DMX Address:** Navigate to the desired DMX address using the UP/DOWN buttons and confirm by pressing ENTER.

**INFO:** Toggle between LED temperature, software version, and serial number by pressing UP/DOWN.

**Display Mode:** After the last button touch, the time selected indicates when the display will turn off. You can also select [ON] and the display will stay illuminated.

- 5 Seconds
- 10 Seconds
- 30 Seconds
- 60 Seconds

**Display Brightness Setting:** Select a value between [0-255].

**Fan:** Choose between automatic fan control or keeping the fan constantly on.

**Man DIM:** Use the UP/ DOWN buttons to enter the manual settings menu. Use UP/ DOWN buttons to select your desired values from [0-255].

**Channel:** Use UP/ DOWN buttons to select your desired channel mode. Press enter to confirm and return to the main menu.

- 1 Channel
- 2 Channel
- 3 Channel

**Perform:** Access preprogrammed colors from 0 to 3.

**Master:** Turn the MASTER Mode On or Off. Turn on master mode to chain the settings from the master unit to the rest of the units in the chain.

## DMX Profiles

---

### Drama EW200 1 Channel Mode

DMX Channel	Function	Description	Value	Init
1	Dimmer	LED Intensity	0-255	255

### Drama EW200 2 Channel Mode

DMX Channel	Function	Description	Value	Init
1	Dimmer	LED Intensity	0-255	255
2	Strobe	No Function	0	0
		Strobe (slow to fast)	1-127	
		Pulse On (slow to fast)	128-159	
		Pulse Off (slow to fast)	160-191	
		Random Strobe (slow to fast)	192-255	

### Drama EW200 3 Channel Mode

DMX Channel	Function	Description	Value	Init
1	Dimmer	Dimmer off to Full	0-255	255
2	Strobe	No Function	0	0
		Strobe (slow to fast)	1-127	
		Pulse On (slow to fast)	128-159	
		Pulse Off (slow to fast)	160-191	
		Random Strobe (slow to fast)	192-255	
2	Dimming Control	Linear Dimming	0-49	0
		Square Law Dimming	50-99	
		Invert Square Law Dimming	100-149	
		S-Type Dimming	150-255	

## Fixture and Lens Assembly

---

After unboxing the fixture and lens, slide the lens into the fixture opening as pictured.

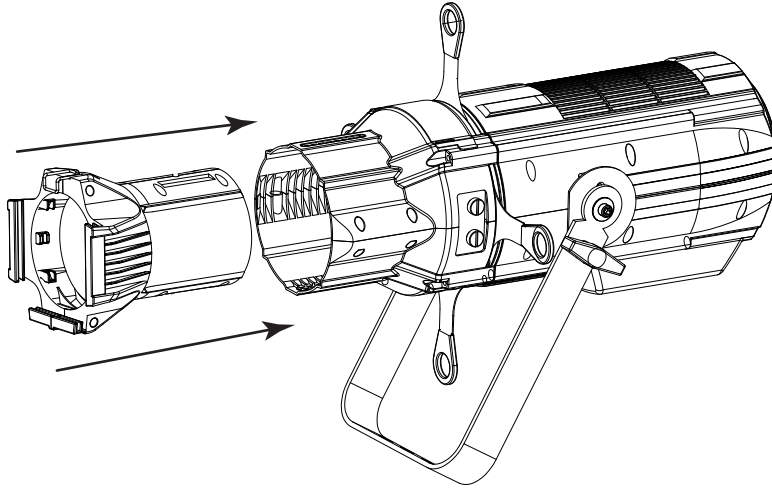

Insert tightening knob and tighten both top and bottom to secure the lens to the fixture. Loosen knobs and adjust lens length to dial in the lens focus, retighten both knobs to secure the lens.

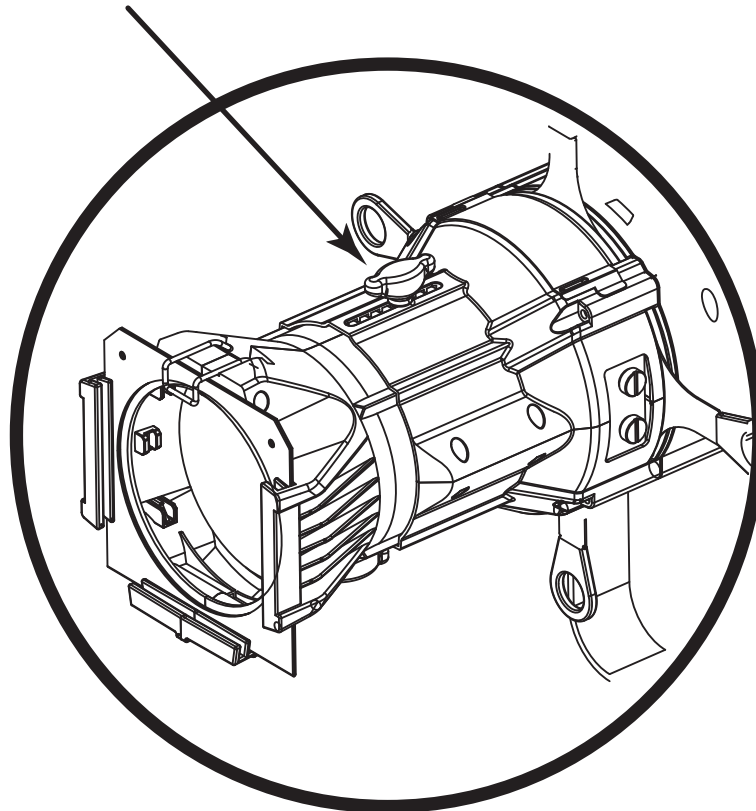

## Gobo and Gel Holder Assembly

Locate the gobo frame and loosen the gobo frame screw. Insert the chosen gobo and lock the gobo frame screw back in place. Finally slide the gobo holder into the gobo frame slot on the top of the fixture.

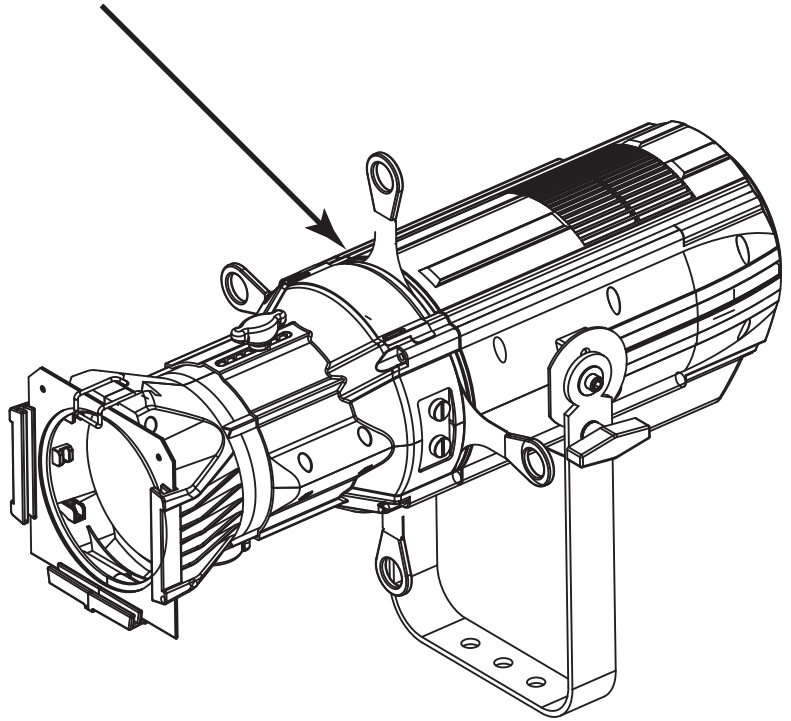
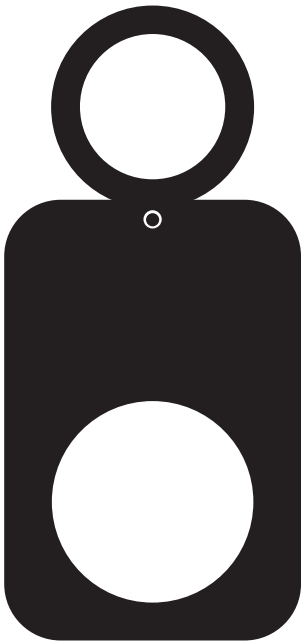

**GOBO Size:** 86mm  
**Image Size:** 62mm  
**Max Thickness:** 2mm

To install the gel holder, remove both screws on the gel holder and insert your color gel. Tighten both screws to secure the gel holder in the frame. Lift the spring clip and slide in the frame. Resecure the spring clip to hold the gel holder in place.

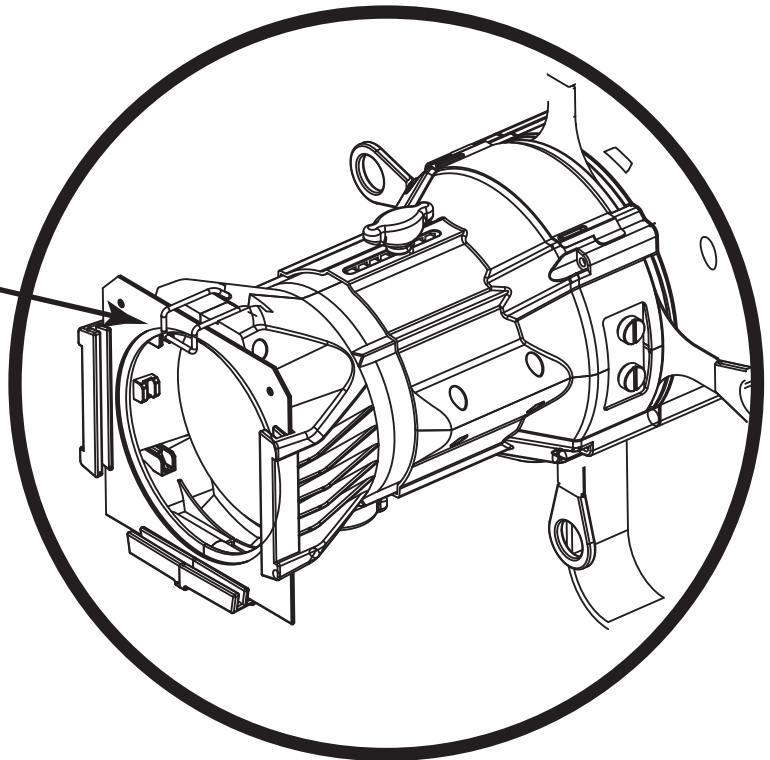



# Size and Weight

Fixture

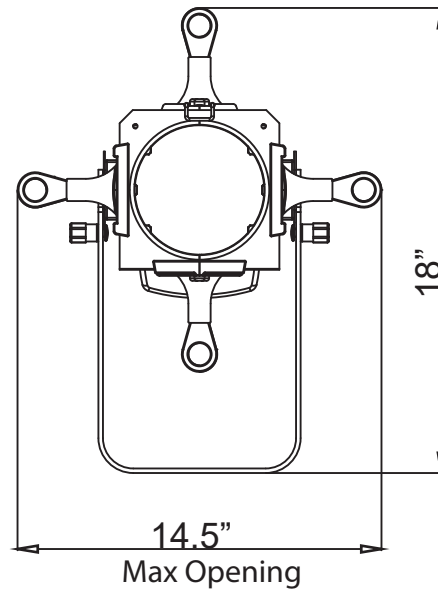
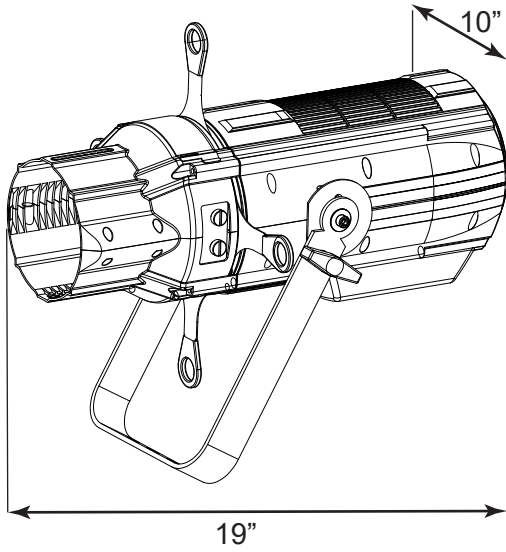

Lens

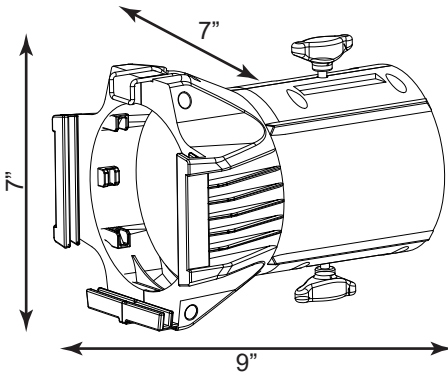

Fixture with Max Length Lens

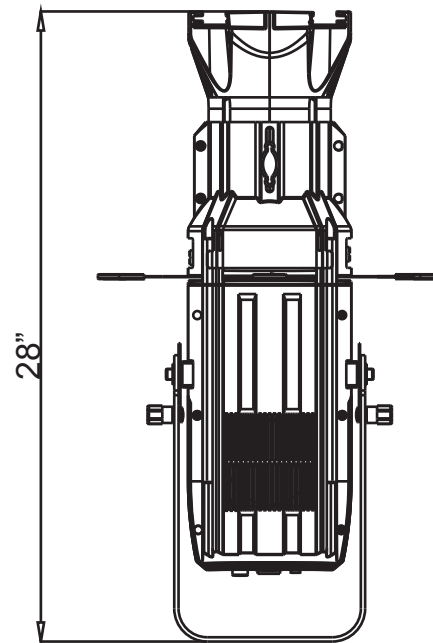

Fixture Size:	28" X 14.5" X 18"
Fixture Weight:	11lb
Packaged Size:	27" X 12" X 12"
Packaged Weight:	16lb

## Parts & Accessories

7063-PCB-MAI	DISPLAY AND MAIN PCB	7062-GEL	GEL HOLDER
7063-PCB-DRI	DRIVER PCB	7062-GOB	GOBO HOLDER
7062-PCB-XLR5	5 PIN XLR PCB CONNECTION	7062-KNO-YOK	MEGA LITE KNOB ON THE YOKE
7062-FAN	FAN DC 12 1.96w	7062-KNO-LEN	MEGA LITE KNOB ON LENS
7063-LED	LED REPLACEMENT	7062-LEN-19	LENS 19 DEGREE ANGLE
7062-BEZ-LEN	LENS PLASTIC	7062-LEN-26	LENS 26 DEGREE ANGLE
7062-BEZ-BOD-BOT	MAIN BODY PLASTIC BOTTOM	7062-LEN-36	LENS 36 DEGREE ANGLE
7062-BEZ-BOD-TOP	MAIN BODY PLASTIC TOP	7062-LEN-50	LENS 50 DEGREE ANGLE

## Installation

---

### Caution!

1. The Installation must be carried out by an authorized dealer or trained professional.
2. Unit may cause severe injuries, if you have doubts concerning the safety do not install.
3. Unit is to be 24 inches away from flammable materials.
4. Use high quality installation equipment to hang the unit.

When rigging the it is very important that you follow common safety procedures. Rigging requires extensive experience including but not limited to calculating working weight loads, material being used and periodic safety inspections. If you lack these qualifications, do not attempt the installation yourself, instead use a professional structural rigger.

When rigging the unit always be secure with a secondary safety attachment. The installation location of the fixture has got to be built in the way that it can hold 10 times the weight for 1 hour with out any failures. Installation should be checked at least one time a year by a skilled professional.

## Cleaning and Maintenance

---

Installation Maintenance- The operator has to make sure that the unit is operating safely and has the installations and electronics checked by an expert every year.

The following points must be considered during the inspection:

- 1) All screws used for installing the device or part of the device have to be tightly connected and must not be corroded.
- 2) There must not be any deformations on the housing, fixation and installation spots (ceiling, suspension, trussing).
- 3) The electronic power supply cables must not show any damages, material fatigue (e.g. porous cables) or sediments. Further instructions depending on the installation spot and usage have to be adhered by a skilled installer and any safety problems have to be removed.
- 4) Fixture housing must only be cleaned from the outside using only soap and water.

**Note:** Maintenance and service operations are to be carried out by authorized dealers.

**Replacing the fuse:** When possible, only replace the fuse with the same type and rating. (F4)

**Replacing the power cable:** If the power cable of this device becomes damaged, it has to be replaced by authorized dealers or trained professionals only.

**Should you have further questions, please contact your dealer.**

## GENERAL TERMS AND CONDITIONS

1. All resellers must have approved and signed Reseller Application on file including their respective state tax information and W-9. Applications are re-evaluated on a fiscal calendar year basis to assure business integrity and tax status.
2. Cash, check, cashiers check, ACH, wire transfer, MasterCard, Visa, Discover and American Express are accepted forms of payment.
3. Past due invoices will be charged 1.5% per month finance charge. Uncollected invoices are subject to be turned over to collection.
4. The reseller will pay all reasonable expenses incurred in the course of collections.
5. The proper venue for litigation will be Bexar County, Texas.
6. Returned checks will be charged a \$50.00 fee.
7. All prices are in U.S. Dollars.
8. All prices and specifications are subject to change without notice, sales order confirmations are emailed and will reflect correct pricing.
9. All terms are insured, monitored, analyzed and approved by Coface USA. Changes in credit line and approved terms can change without notice. Company authorization of credit is based on Coface approvals. Any conflicts or disagreements should be referred to:  
650 College Rd. East Suite 2005 Princeton, NJ 08540. 1-609-469-0400. E-mail: [cofaceusa@coface.com](mailto:cofaceusa@coface.com)
10. Returns are subject to 25% restocking charge plus any necessary charges for repair or re-packaging.

## SHIPPING TERMS AND CONDITIONS

1. All orders are EXW San Antonio, TX (EXW means that a buyer/reseller incurs the risks for bringing the goods to their final destination). Any deviation needs to be done in writing.
2. UPS ground shipping is the preferred shipping method. Requests for specific carriers may require use of the customer's account number and may incur an additional charge for handling.
3. Drop shipments are subject to all return charges at reseller's expense. Drop shipments are not allowed outside of the territorial United States.
4. No C.O.D. shipments allowed.
5. Returned and undelivered shipment charges are the buyer/reseller's responsibility and will be billed to the buyer/reseller.
6. The freight carrier and company [shipping@mega.lighting](mailto:shipping@mega.lighting) should be notified upon receipt of damaged freight, discrepancies or non-conformities within 24 hours. Company can assist in making claims with carriers or agents in the event of any loss or damage.

## WARRANTY AND SERVICE PROCEDURES

1. All returns require an RMA# (Return Merchandise Authorization number) before returning goods for any reason. For a service or warranty RMA, please email [service@mega.lighting](mailto:service@mega.lighting) or call 210-684-2600. For sales or demo returns, please contact [sales@mega.lighting](mailto:sales@mega.lighting).
2. Case will be created and an RMA notice will be emailed. All units received must have the RMA # included with the unit as well as on the shipping label.
3. All shipping charges are the responsibility of the customer: MEGA Systems, Inc., Service, 18668 HWY 16 N, Helotes, TX 78023.

## WARRANTY FOR PRODUCTS PURCHASED BEFORE 2021

Unless otherwise stated in writing, product is covered by a **one year parts and labor** limited warranty and is subject to same limitation listed under the limited warranty exclusions listed below.

## WARRANTY FOR PRODUCTS PURCHASED AFTER JANUARY 1, 2021

**MEGA SYSTEMS INC** ("MSI") hereby warrants to the original purchaser/owner ("Customer"), MSI products to be free of manufacturing defects in material and workmanship, for the warranty periods as defined below from the original purchase invoice date. This warranty applies exclusively to new MSI branded and/or distributed products listed below, purchased from an MSI AUTHORIZED dealer/reseller. This warranty is not transferable and may or may not apply to products sold and/or forwarded outside the United States. Please contact MSI for applicable regional product warranty information. The purchase of MSI product constitutes the Customer's acceptance of all warranty terms and conditions as listed in this limited warranty statement. This warranty provides the Customer with legal rights which may vary from state to state. Please contact MSI regarding warranty questions prior to purchasing.

Product / Series	Warranty Period	Coverage
BATTERY POWERED LED	Six month battery one year all other components	1, 2
MOVING LED, HAZERS	One year	2
OUTDOOR IP RATED LED	Two Year	3
HOUSE LIGHT LED, DECORATIVE LED, COMPACT LED, ICANDY LED, THEATRICAL LED, STROBE WASH LED, FOLLOW SPOT LED, PRODUCTION & HOUSE OF WORSHIP CONTROL, ARCHITECTURAL CONTROL, THEATRICAL CONTROL, DANCE VENUE & MOBILE DJ CONTROL, DIRECT VIEW LED DISPLAYS, AND MV CONTROLERS	Three Year	4

**1. Battery, 183 days six months 2. Parts and Labor, 365 days one year 3. Parts and Labor, 730 days two year 4. Parts and Labor, 1095 days three year**

**This limited warranty excludes any defects caused by, resulting from or relating to the following:**

- Normal wear and tear of lamps, color media, brushes, contact rings, lamp sockets, belts and other parts prone to wear and tear.
- Misuse, abuse, improper handling, accident, alteration or attempts to repair by or on behalf of the owner or any person not authorized by MSI.
- Damage to the product resulting from acts of God, including, but not limited to, earthquakes, hurricanes, tornados, lightning and other natural disasters, fire, explosion, flood, riots, civil disorder or any other cause beyond the reasonable control of MSI.
- Exposure to harsh or excessively corrosive environmental conditions (whether indoors or outdoors), including, but not limited to, extreme temperatures, humidity, atmospheric conditions (including salinity or pressure), radiation (UV, infrared or nuclear), shock and conditions which exceed the product's Ingress Protection ("IP") rating.
- Use of the product in a manner which exceeds the applicable product specification, including, but not limited to, exposure to excessive, insufficient or other voltage conditions.
- Installation or use of the product not in accordance with the technical documentation, MSI guidelines (as may be posted on its website at [www.megasystemsinc.com](http://www.megasystemsinc.com) from time to time or otherwise designated by MSI or its brands) or applicable building and electrical codes, regulations and standards.
- Failure to maintain the product in accordance with the technical documentation.
- Natural degradation and color shift of the LED source over the course of normal product use.
- Slight deviations in the specified values of intensity and color that do not affect the functionality of the product.
- Use of the product not for its intended purpose.

All warranty claims are evaluated under the terms of this limited warranty. If a product falls within the warranty period and if, upon examination by MSI it is found to have failed for a covered cause, MSI will, at its sole discretion, repair or replace the defective part or product or reimburse the purchaser a pro-rated portion of the purchase price based on the percentage of the warranty period still remaining as of the date that the returned product was received by MSI. Should a replacement part or product be discontinued or unavailable, MSI reserves the right, in its sole and absolute discretion, to substitute a comparable replacement part or product for the defective part or product. MSI warranty obligation hereunder is limited solely to the repair or replacement of or reimbursement for the particular parts or products determined by MSI to have failed for a covered cause within the warranty period. In no event shall MSI be responsible to replace or reimburse purchaser for any products or portions of a system that MSI determines has not failed for a covered cause within the warranty period, even if such other products or portions of a system are used together with products being repaired or replaced by MSI under this warranty and the repaired product differs in brightness, colors or any other attribute after the repair.

Costs of removal, shipping to MSI or its authorized representative and reinstallation are solely the responsibility of the purchaser. If MSI determines that the product is covered by this limited warranty, it will only pay for parts and labor as indicated by product type. If MSI determines that the product is not covered by this limited warranty, the purchaser will have the option of paying for the repair (if the product can be repaired) and the purchaser shall be responsible for the cost of shipping the repaired product back to the purchaser. MSI reserves the right, in its sole and absolute discretion, to decline any repair.

**IN NO EVENT SHALL MEGA SYSTEMS, INC. BE LIABLE FOR ANY INCIDENTAL, CONSEQUENTIAL, SPECIAL, INDIRECT OR PUNITIVE LOSS OR DAMAGE OF ANY KIND, INCLUDING, BUT NOT LIMITED TO, LOSS OF PROFITS OR REVENUES, LOSS OF USE OF THE PRODUCT OR ANY OTHER GOODS OR ASSOCIATED EQUIPMENT, DAMAGE TO ANY ASSOCIATED EQUIPMENT, COST OF CAPITAL, COST OF SUBSTITUTE PRODUCTS, FACILITIES OR SERVICES, DOWN TIME COST, INSTALLATION OR LABOR COSTS, OR CLAIMS OF THE PURCHASER'S CUSTOMERS, WHETHER BASED ON WARRANTY, CONTRACT OR NEGLIGENCE, ARISING IN CONNECTION WITH THE SALE, USE OR REPAIR OF THE PRODUCT. MEGA SYSTEMS INC'S MAXIMUM LIABILITY SHALL NOT, IN ANY CASE, EXCEED THE PURCHASE PRICE OF THE PRODUCT THAT GIVES RISE TO THE CLAIM.**

**EXCEPT FOR THE LIMITED WARRANTY SET FORTH HEREIN, ALL PRODUCTS SOLD BY MEGA SYSTEMS, INC. ARE SOLD "AS IS" WITHOUT ANY WARRANTY, EXPRESS OR IMPLIED, STATUTORY OR OTHERWISE, INCLUDING, BUT NOT LIMITED TO, IMPLIED WARRANTIES OF MERCHANTABILITY AND FITNESS FOR A PARTICULAR PURPOSE, ALL OF WHICH ARE EXPRESSLY AND SPECIFICALLY DISCLAIMED BY MEGA SYSTEMS, INC.**

## Customer Support

---

MEGA Lite has a customer support line to provide set-up help and to answer any questions should you encounter a problem. Please visit our website for any other related technical documents. For service related issues, please contact our service dept.

Monday - Friday 9am to 6pm CST  
(210) 684-2600  
service@mega.lighting

## Manual Version

---

Please visit [www.mega.lighting](http://www.mega.lighting) for the most up-to-date manual version.

Manual Version	Date	Fixture Software	Notes
1.0	7/17/2024	1.0	



MEGA LITE  
18662 Bandera Rd  
Helotes, TX 78023  
Phone (210)684-2600 / Fax (210)855-6279  
[www.mega.lighting](http://www.mega.lighting) / [info@mega.lighting](mailto:info@mega.lighting)